

Xiangli™

RAISED FLOOR SYSTEM

Data center & Office building solution

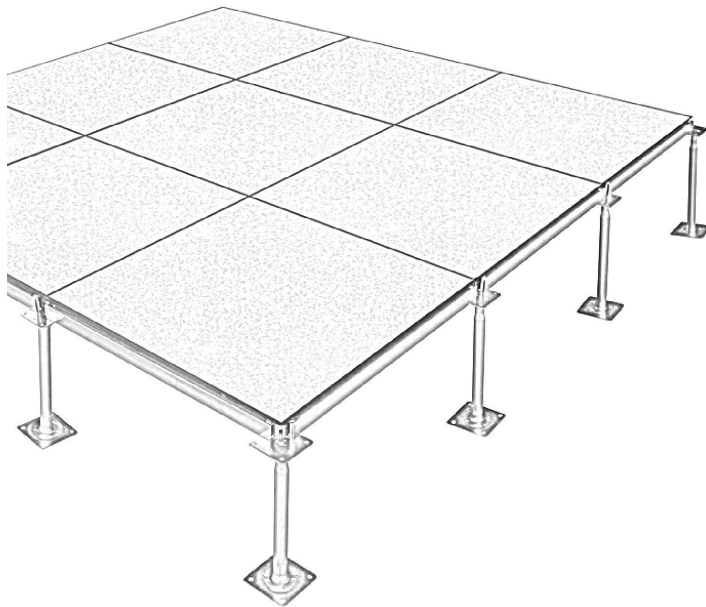

Xiangli™

XIANGLI ANTI-STATIC DECORATIVE MATERIAL CO., LTD. (JIANGSU)

E-mail: sales@xlraisedfloor.com

TEL: 86-519-88611016

FAX: 86-519-88611026

Web: www.xlraisedfloor.com

ADD: 129 Eastern Dongfang Road, Changzhou,
Jiangsu, China P.C: 213025

**Xiangli Raised Floor, Access To Success.
Since 1996**

www.xlraisedfloor.com



Contents

Company Introduction

Xiangli Anti-static Decorative Material Co.,Ltd(Jiangsu) established in 1996, is a professional raised access floor manufacturer.

With the factory area of 85000m², Xiangli manufactures 2,000,000 square meters of floorings every year. There are 280 staffs cooperating harmoniously in our Xiangli Factory.

Xiangli has developed good business to Germany, Spain, UK, USA, Canada, UAE, Korea, Qatar, Japan, Vietnam, Russia, Australia, Brazil, South Africa, Argentina, Chile, etc 120 countries around the world.

Xiangli has obtained more than 20 patents. Xiangli has won the certificates of ISO9001, ISO14001, CE EN12825, EN13501, BS476, CISCA, MOB and so on.

- 01 Company introduction
- 03 Production capacity
- 04 Patent, certificate, quality control
- 05 Cement infilled steel raised access floor (Finished type)
- 06 Cement infilled steel raised access floor (Ceramic finish)
- 07 Cement infilled steel raised access floor (Bare finish)
- 09 Cement infilled steel raised access floor (Bare finish)
Trunking system
- 10 Cement infilled steel raised access floor (Bare finish)
XLOA trunking system
- 11 Calcium sulphate raised access floor (Finish type)
- 12 Steel encased calcium sulphate raised access floor
- 13 Wood core raised access floor (Finish type)
- 14 Steel encased wood core raised access floor
- 15 Aluminum raised access floor
Air-flow raised access floor system in all aluminum
- 16 Air-flow raised access floor system in all steel
- 17 Wire mesh cable tray & Fiber cable tray
- 18 Magnetic carpet
- 19 How to choose pedestal?
- 21 Accessories--Pedestal & Stringer
(Electro-galvanized / Hot galvanized / Electrophoretic paint)
- 22 Accessories (electrical outlet, panel lifters, grommets etc..)
- 23 Typical project
- 25 Tiles (HPL/PVC/Ceramic/Carpet color chart)
- 26 Construction disposal and use notice & Maintenance

Production Facility



Patents



Certificates



Quality Control

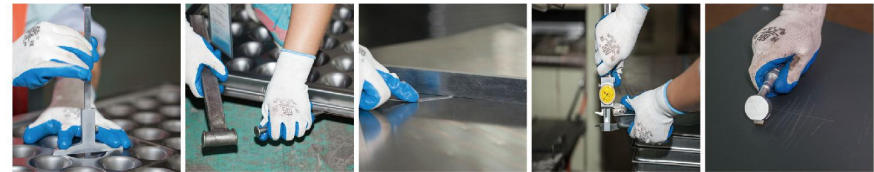

Cement Infilled Steel Raised Access Floor (Finished Type)

XLF-600/610

» Characteristics

- HPL/PVC/Ceramic/Granite/Carpet finished.
- Multifunction: anti-static,dust- proof, anti-skid, anti-rust, anti-corrosion.
- Patent design "cross strengthening rib" providing high dimensional precision.
- High performance solution for under-floor air conditioner.
- Used for computer, data center, communication center, laboratory, micro-electronics work shop, power plant, etc.

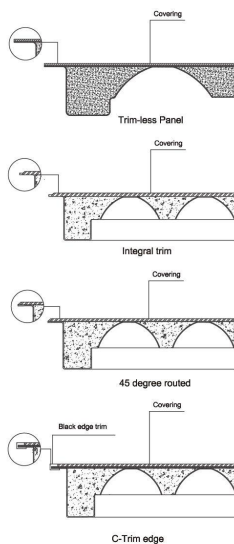
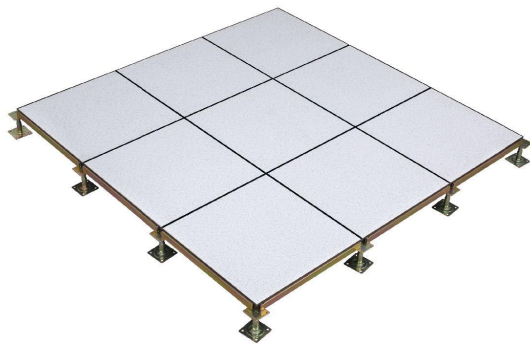

» Structure

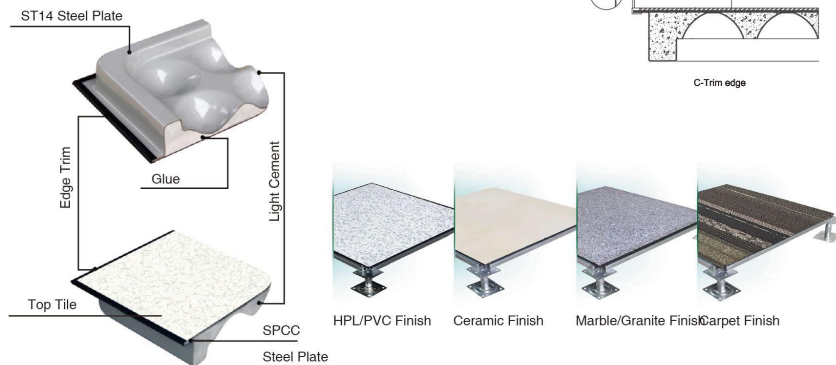

Cement Infilled Steel Raised Access Floor (Ceramic Finish)

» Characteristics

- Dirt-proof
- Anti-static and not anti-static optional
- No cracking
- High concentrated loading performance and appearance

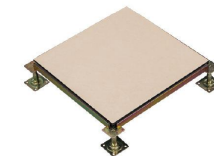

For office use

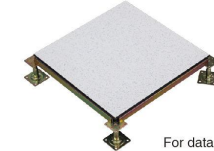

For data center use

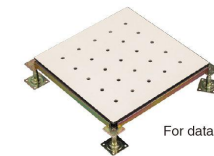

For data center use

Note: Concentrated load from FS800 to FS1500

» Technical Specification

Type International	Concentrated load			Impact load N	Ultimate load N	Uniform load N/m ²	Rolling load	
	LB	N	Kg				10 times	10000 times
XL-F-440 (FS440)	≥ 440	≥ 1960	≥ 200	≥ 295	≥ 5880	≥ 9720	≥ 1958	≥ 1566
XL-F-662 (FS662)	≥ 662	≥ 2950	≥ 301	≥ 445	≥ 8850	≥ 12500	≥ 2948	≥ 2356
XL-F-800 (FS800)	≥ 800	≥ 3550	≥ 363	≥ 538	≥ 11250	≥ 16100	≥ 3560	≥ 2670
XL-F-1000 (FS1000)	≥ 1000	≥ 4450	≥ 453	≥ 670	≥ 13350	≥ 23000	≥ 4450	≥ 3560
XL-F-1250 (FS1250)	≥ 1250	≥ 5560	≥ 567	≥ 670	≥ 16680	≥ 33000	≥ 5560	≥ 4450
XL-F-1500 (FS1500)	≥ 1500	≥ 6660	≥ 680	≥ 780	≥ 26690	≥ 43000	≥ 6670	≥ 5560
XL-F-2000 (FS2000)	≥ 2000	≥ 8880	≥ 906	≥ 890	≥ 31130	≥ 58000	≥ 8800	≥ 8000

Cement Infilled Steel Raised Access Floor
(Bare Finish)

XLB-500/600/610

» Characteristics

- Dust proof, shock proof, anti-rust and strong load capacity
- Patent design for "cross strengthening rib"
- Adjustable height for wire laying and good exchange-ability
- Widely used in office building



500x500

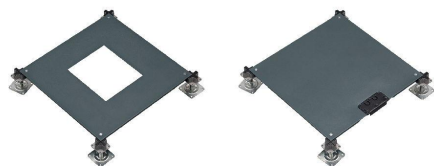

Panel with grommet hole easy for wire

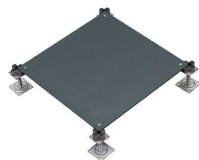

Panel without grommet hole



500x500

How to choose pedestal? Please see page 19-20.

Cement Infilled Steel Raised Access Floor
(Bare Finish)

600x600



Bent edge



Flat edge



600x600

Patent Design Cross Strengthening Rib

- 10-30% more loading capacity.
- 10% flatness improved.
- Advanced in appearance.

Concave Rib

- Strengthening the load bearing of panel side.
- Wider edge for excellent side load performance.

» Technical Specification

Type International	Concentrated load			Impact load N	Ultimate load N	Uniform load N/m ²	Rolling load	
	LB	N	Kg				10 times	10000 times
XL-F-440 (FS440)	≥ 440	≥ 1960	≥ 200	≥ 295	≥ 5880	≥ 9720	≥ 1958	≥ 1566
XL-F-662 (FS662)	≥ 662	≥ 2950	≥ 301	≥ 445	≥ 8850	≥ 12500	≥ 2948	≥ 2356
XL-F-800 (FS800)	≥ 800	≥ 3550	≥ 363	≥ 538	≥ 11250	≥ 16100	≥ 3560	≥ 2670
XL-F-1000 (FS1000)	≥ 1000	≥ 4450	≥ 453	≥ 670	≥ 13350	≥ 23000	≥ 4450	≥ 3560
XL-F-1250 (FS1250)	≥ 1250	≥ 5560	≥ 567	≥ 670	≥ 16680	≥ 33000	≥ 5560	≥ 4450
XL-F-1500 (FS1500)	≥ 1500	≥ 6660	≥ 680	≥ 780	≥ 26690	≥ 43000	≥ 6670	≥ 5560
XL-F-2000 (FS2000)	≥ 2000	≥ 8880	≥ 906	≥ 890	≥ 31130	≥ 58000	≥ 8800	≥ 8000

Cement infilled steel raised access floor (Bare finish)
Trunking system

XLT-500/600/610

» Characteristics

- Flexible trunks for wires and cables.
- High recycled, convenient removing.
- Long performance life.

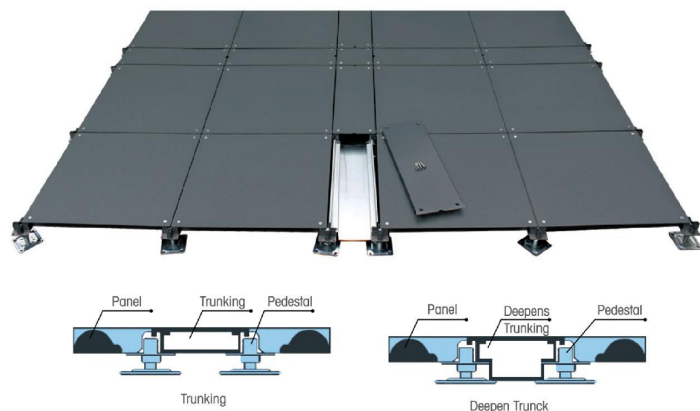

» Technical Specification

Type International	Concentrated load			Impact load N	Ultimate load N	Uniform load N/m ²	Rolling load	
	LB	N	Kg				10 times	10000 times
XL-T-440 (FS440)	≥440	≥1960	≥200	≥295	≥5880	≥9720	≥1958	≥1566
XL-T-662 (FS662)	≥662	≥2950	≥301	≥445	≥8850	≥12500	≥2948	≥2356
XL-T-800 (FS800)	≥800	≥3550	≥363	≥538	≥11250	≥16100	≥3560	≥2670
XL-T-1000 (FS1000)	≥1000	≥4450	≥453	≥670	≥13350	≥23000	≥4450	≥3560
XL-T-1250 (FS1250)	≥1250	≥5560	≥567	≥670	≥16680	≥33000	≥5560	≥4450
XL-T-1500 (FS1500)	≥1500	≥6660	≥680	≥780	≥26690	≥43000	≥6670	≥5560
XL-T-2000 (FS2000)	≥2000	≥8880	≥906	≥890	≥31130	≥58000	≥8800	≥8000

Cement infilled steel raised access floor (Bare finish)
XLOA trunking system

XLST-500

» Characteristic

- Environment friendly and energy saving.
- Main components, panel, trunk cover plate, corner bottom plate.
- It is adjustable, the best height is 35mm, saving the space of room.
- Easy for wiring and cabling four corner lock holes.



» Structure

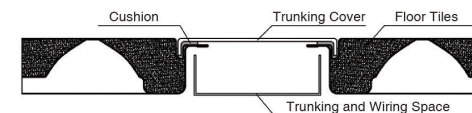

• Save the room space, the lowest height is 35mm, adjustment height is 35-150mm.

» Technical Specification

Type International	Concentrated load			Impact load N	Ultimate load N	Uniform load N/m ²	Rolling load	
	LB	N	Kg				10 times	10000 times
XL-ST-440 (FS440)	≥440	≥1960	≥200	≥295	≥5880	≥9720	≥1958	≥1566
XL-ST-662 (FS662)	≥662	≥2950	≥301	≥445	≥8850	≥12500	≥2948	≥2356
XL-ST-800 (FS800)	≥800	≥3550	≥363	≥538	≥11250	≥16100	≥3560	≥2670
XL-ST-1000 (FS1000)	≥1000	≥4450	≥453	≥670	≥13350	≥23000	≥4450	≥3560
XL-ST-1250 (FS1250)	≥1250	≥5560	≥567	≥670	≥16680	≥33000	≥5560	≥4450
XL-ST-1500 (FS1500)	≥1500	≥6660	≥680	≥780	≥26690	≥43000	≥6670	≥5560

Calcium Sulphate Raised Access Floor (Finished Type)

XLC600 (30-40mm thickness alternative)

» Characteristics

- Environment friendly and 100% recycle
- Antistatic, fireproof, high loading & flatness, shockproof.
- Adjustable height for pedestal, assembly agility, large wire, good exchangeability
- Outlet mating. Elegant appearance for paving widely brand top tiles.
- Being stable performance in humidity & temperature.



» Technical Specification

Type International	Concentrated load			Impact load N	Ultimate load N	Uniform load N/m ²	Rolling load	
	LB	N	Kg				10 times	10000 times
XL-C-800 (FS800)	≥ 800	≥ 3550	≥ 363	≥ 538	≥ 11250	≥ 16100	≥ 3560	≥ 2670
XL-C-1000 (FS1000)	≥ 1000	≥ 4450	≥ 453	≥ 670	≥ 13350	≥ 23000	≥ 4450	≥ 3560
XL-C-1250 (FS1250)	≥ 1250	≥ 5560	≥ 567	≥ 670	≥ 16680	≥ 33000	≥ 5560	≥ 4450
XL-C-1500 (FS1500)	≥ 1500	≥ 6660	≥ 680	≥ 780	≥ 26690	≥ 43000	≥ 6670	≥ 5560
XL-C-2000 (FS2000)	≥ 2000	≥ 8880	≥ 906	≥ 890	≥ 31130	≥ 58000	≥ 8800	≥ 8000

Steel Encased Calcium Sulphate Raised Access Floor

XLEC-500/600 Thickness 26mm/31mm

» Characteristics

- Galvanized steel plate encased the calcium sulphate core panel
- Steel sealed edge
- Excellent load performance
- 500*500*26mm and 600*600*31mm optional

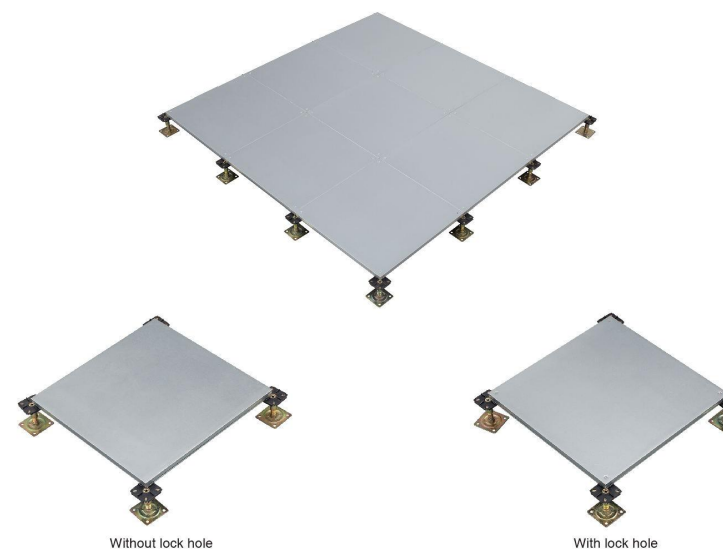

» Technical Specification

Type International	Concentrated load			Impact load N	Ultimate load N	Uniform load N/m ²	Rolling load	
	LB	N	Kg				10 times	10000 times
XL-EC-1000 (FS1000)	≥ 1000	≥ 4450	≥ 453	≥ 670	≥ 13350	≥ 23000	≥ 4450	≥ 3560
XL-EC-1250 (FS1250)	≥ 1250	≥ 5560	≥ 567	≥ 670	≥ 16680	≥ 33000	≥ 5560	≥ 4450
XL-EC-1500 (FS1500)	≥ 1500	≥ 6660	≥ 680	≥ 780	≥ 26690	≥ 43000	≥ 6670	≥ 5560
XL-EC-2000 (FS2000)	≥ 2000	≥ 8880	≥ 906	≥ 890	≥ 31130	≥ 58000	≥ 8800	≥ 8000

Wood Core Raised Access Floor (Finished Type)

XLW600

» Characteristics

- 30/38mm high quality chipboard core with galvanized steel reinforcement underneath.
- Four pieces black PVC sealed the core
- Covering:HPL,PVC,Steel,Carpet,Ceramic
- Accessories die casting steel structure pedestal plastic gasket on top, height could be 80mm~1500mm, with or without square tube stringer steady connect the system.

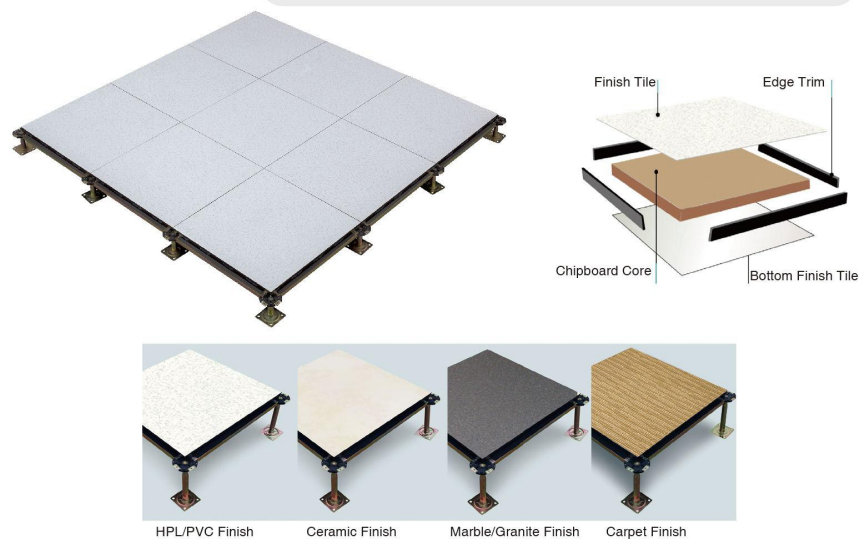

» Technical Specification

Type International	Concentrated load			Impact load N	Ultimate load N	Uniform load N/m²	Rolling load	
	LB	N	Kg				10 times	10000 times
XL-W-440 (FS440)	≥440	≥1960	≥200	≥295	≥5880	≥9720	≥1958	≥1566
XL-W-662 (FS662)	≥662	≥2950	≥301	≥445	≥8850	≥12500	≥2948	≥2356
XL-W-800 (FS800)	≥800	≥3550	≥363	≥538	≥11250	≥16100	≥3560	≥2670
XL-W-1000 (FS1000)	≥1000	≥4450	≥453	≥670	≥13350	≥23000	≥4450	≥3560
XL-W-1250 (FS1250)	≥1250	≥5560	≥567	≥670	≥16680	≥33000	≥5560	≥4450
XL-W-1500 (FS1500)	≥1500	≥6660	≥453	≥780	≥26690	≥43000	≥6670	≥5560

Steel Encased Wood Core Raised Access Floor

XLEW-500/600

» Characteristics

- Galvanized steel plate encased the calcium sulphate core panel
- Six sides Galvanized
- 500*500*28mm and 600*600*31mm for optional

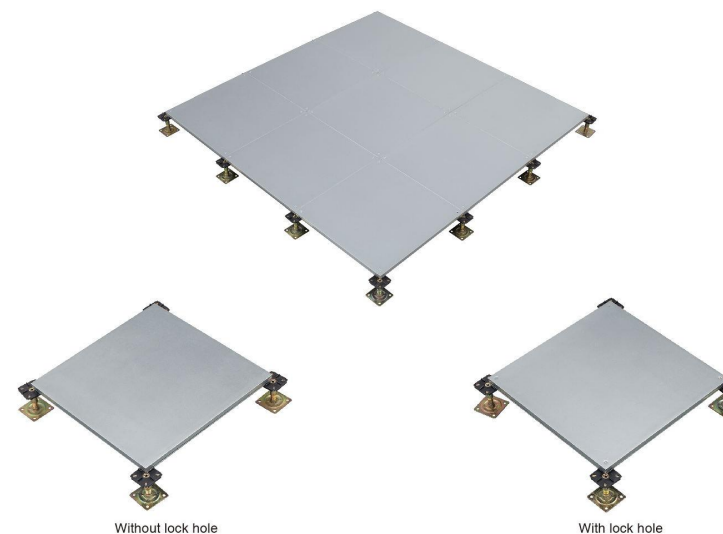

» Technical Specification

Type International	Concentrated load			Impact load N	Ultimate load N	Uniform load N/m²	Rolling load	
	LB	N	Kg				10 times	10000 times
XL-EW-662 (FS662)	≥662	≥2950	≥301	≥445	≥8850	≥12500	2946	2356
XL-EW-800 (FS800)	≥800	≥3550	≥363	≥536	≥11250	≥16100	3560	2670
XL-EW-1000 (FS1000)	≥1000	≥4450	≥453	≥670	≥13350	≥23000	4450	3560
XL-EW-1250 (FS1250)	≥1250	≥5560	≥567	≥670	≥16680	≥33000	5560	4450
XL-EW-1500 (FS1500)	≥1500	≥6860	≥680	≥780	≥26690	≥43000	6670	5560

Aluminum Raised Access Floor System

Conductive Aluminum Raised Access Floor



» Characteristics

- 100% recycled.
- Full aluminum, die casting, top with HPL/PVC.
- Light but high loading ability, high dimension precision.
- Adjustable height for pedestal, assembly agility, large wire, good exchange- ability.
- Long performance life.
- Air-flow panel suitable 15%-55% ventilation.

» Application

Wide range all manner of electronic workshop, clean room, dustless chamber etc.

» Technical Specification For Blind Panel

Type International	Size (mm)	Concentrated load			Impact load N	Ultimate load N	Uniform load N/m ²	Rolling load	
		LB	N	Kg				10 times	10000 times
XLA-1000(FS1000)	600X600	≥1000	≥4450	≥301	≥670	≥13350	≥23000	4450	3560
XLA-1250(FS1250)	600X600	≥1250	≥5560	≥363	≥670	≥16680	≥33000	5580	4450
XLA-1500(FS1500)	600X600	≥1500	≥6660	≥453	≥780	≥26690	≥43000	6670	5560

Air-Flow Raised Access Floor System In All Aluminum

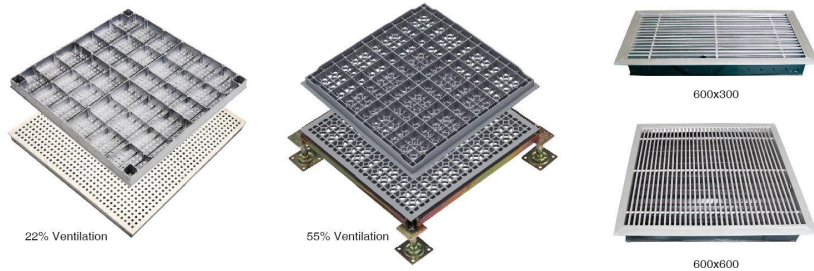

Air-Flow Raised Access Floor System In All Steel

Solution for Data Center/Computer Room/Server Room

» Characteristics

- Made of all steel
- Ventilation from 15-75%
- Fit in steel, wood core, calcium sulphate and aluminum flooring system
- Covering HPL,PVC,Ceramic,Granite etc.

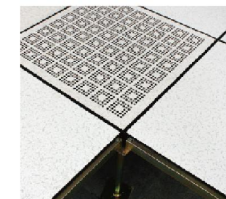

» Application

All manner of computer room, network service room, monitor control center, electronic workshop, clean room, dustless chamber etc and occasions which require on anti-static and air conditioning.

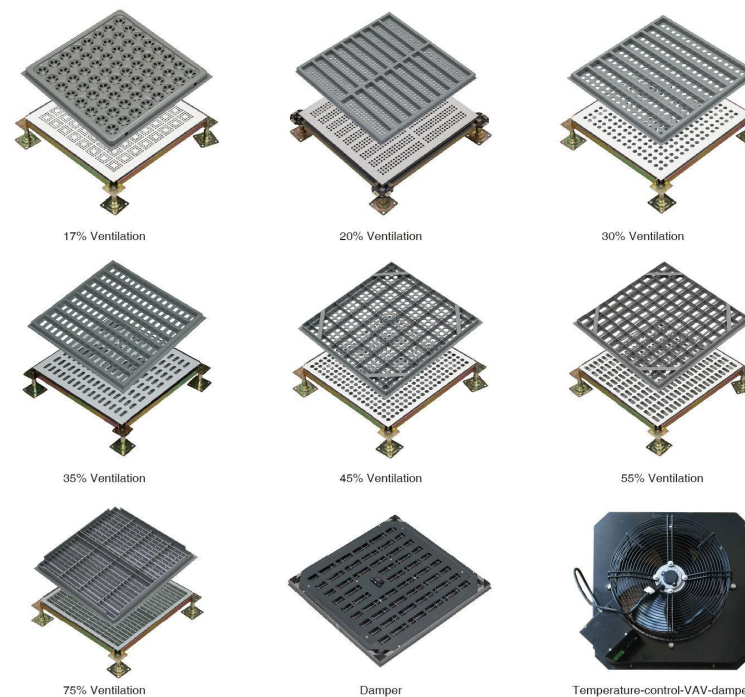

Wire Mesh Cable Tray & Fiber Channel

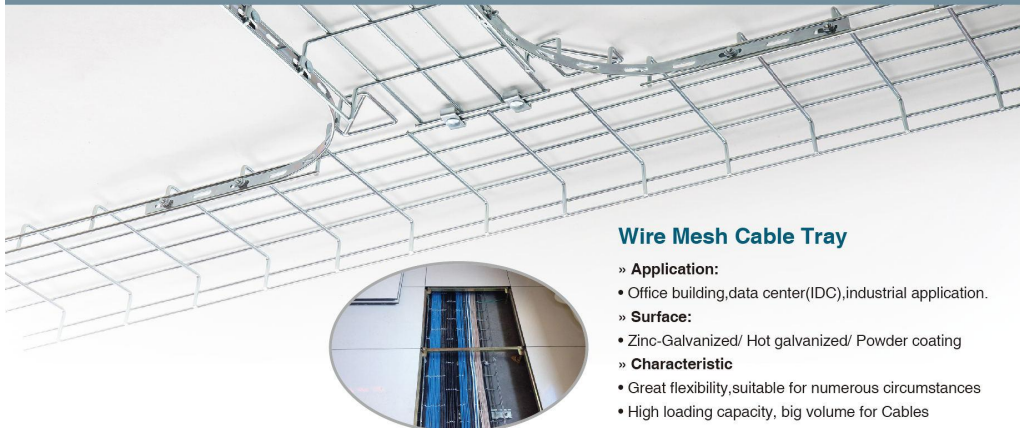
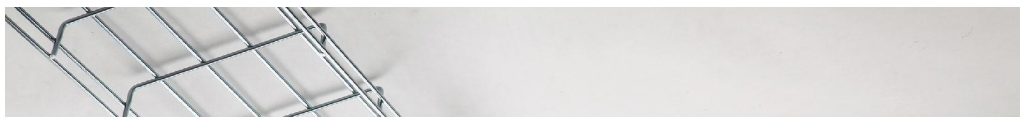

Wire Mesh Cable Tray

- » **Application:** Office building, data center(IDC), industrial application.
- » **Surface:** Zinc-Galvanized/ Hot galvanized/ Powder coating
- » **Characteristic**
 - Great flexibility, suitable for numerous circumstances
 - High loading capacity, big volume for Cables

Item	Height(mm)	Width(mm)	Length(mm)	Dia(mm)	Weight(kg)
XLCT50-50	50	50	3000	5.0	3.14
XLCT50-100	50	100	3000	5.0	3.84
XLCT50-150	50	150	3000	5.0	4.54
XLCT50-200	50	200	3000	5.0	5.25
XLCT50-300	50	300	3000	5.0	6.65
XLCT50-400	50	400	3000	5.0	8.06

Fiber Cable tray

- » Applied to manage fiber-optic cable, provide efficient management on OFCS.
- » Characteristic: Made of ABS material, fire-resistant

Item	Height(mm)	Width(mm)	Length(mm)
XLCF120	100	120	2000
XLCF240	100	240	2000

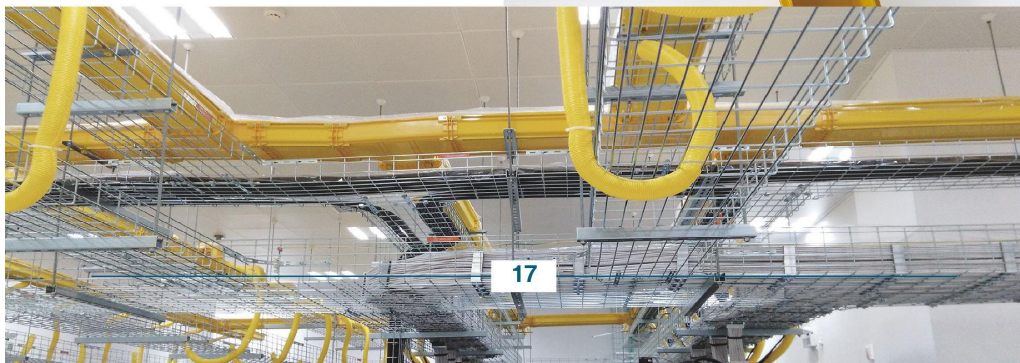

Magnetic Carpets



Patent Design
Patent No.:
ZL 2009 2 0234467.7

Under The Magnetic Carpet is Cement Infilled Steel Raised Floor (Bare finish)

» Characteristic

- Using advanced technology.
- No need glue to paste with steel panels, 100% environment friendly.
- Adsorbed on the surface of panels conveniently and freely, easy to install and remove, saving much manpower, increasing efficiency.
- Colors to select, enjoy DIY fun.
- Easy to cut for grommet hole or any required shapes.

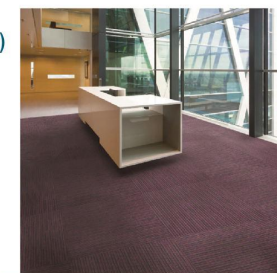

OA network floor

How To Choose Pedestals?

1. Bare Finish Steel Raised Floor System

FFH < 20CM



20cm ≤ FFH ≤ 30cm



FFH > 30cm



2. Bare Finish Steel Raised Floor With Super Low trunking system

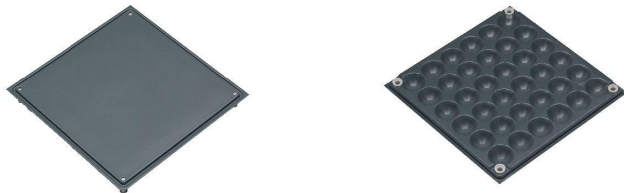

How To Choose Pedestals?

3. Finished Type Raised Floor System

FFH ≤ 60cm

Flat head pedestal stringer system

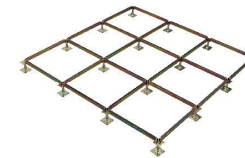

60cm ≤ FFH ≤ 80cm

Super strong flat head pedestal stringer system



FFH > 80cm

Super strong Flat Head pedestal with bracing system



4. Steel Encased Wood Core/Calcium Sulphate Raised Floor System

Without Lock Hole

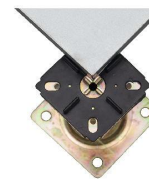

Flat Head Pedestal System

With Lock Hole system



Without Lock Hole



Strengthened Round Head Pedestal System

With Lock Hole system



Without Lock Hole



Round Pedestal & Stringer System

With Lock Hole system

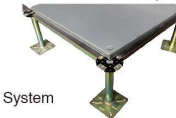

Accessories--Pedestal & Stringer
(Electro-galvanized / Hot galvanized / Electrophoretic paint)

Pedestal



Stringer

Floor stringer is made of standard square tube, Surface galvanized layer thickness is 8-12 μm; Galvanized layer adhesion could be to the highest level of 0; salt spray test for 72 hours, no rust corrosion phenomena.

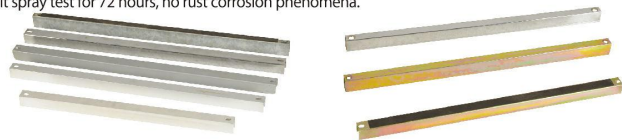

Subsidiary Supporting Accessories

Diagonal brace, tie rod and the hoop as support auxiliary connectors, generally use with super high, super strong pedestal and computer room grounding to reinforce floor installation structure stability and equipotential grounding requirements.



Accessories

Electrical outlet



Panel lifters & Outlet Box



Air Diffuser & Grommet

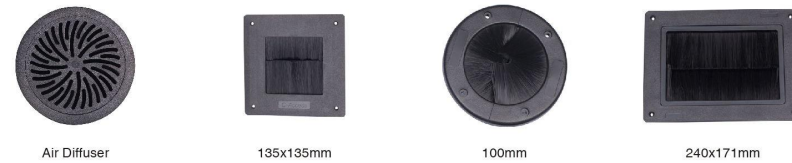

Installation Tools



Typical Project
Office Building



QATAR AL JASRA TWIN TOWERS



Azerbaijan socar tower



Jumeirah-Emirates-Towers

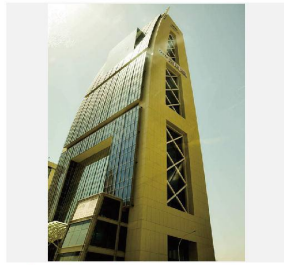

Saudi Arabia AL Munajem Office Tower



Russia Yekaterinburg Bank



HUAWEI Project



ZTE Reserch & Development center

Xiangli™
Data Center Project



China Telecom data center

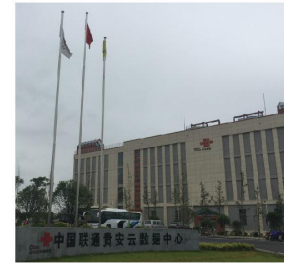

China Unicom data center



China Mobile data center



Ashgabat-Olympic-Complex-turkmenistan

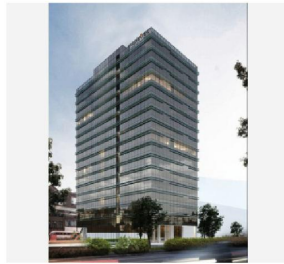

Tiger Office Ho Chi Minh, Vietnam



Mongolia Khan Bank Tower

Public transits & Other Project



Beijing Capital airport- T3 terminal



Shenzhen North Railway Station



Hungary Spirit Hotel (Czech Republic)

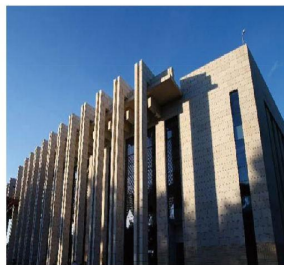

Tanzania Nyerere international conference center



Korea Expressway Corporation New Building



Big data industrial park(Gui Yang)



ShanTou Broadcast and TV center



Satellite launch center(in GanSu)

Tiles (HPL/PVC/Ceramic/Carpet color chart)

» Conductive PVC Color

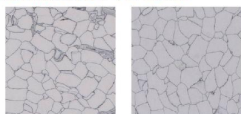

XL-04

XL-05

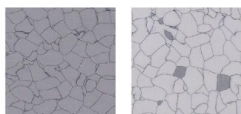

XL-06

XL-07

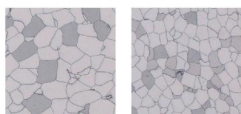

XL-09

XL-11

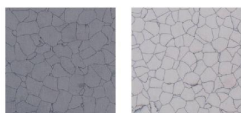

XL-12

XL-13

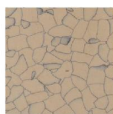

XL-15

» Decorative PVC Tile

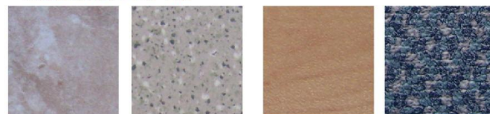

0802

0811

0861

0888

» Ceramic Color

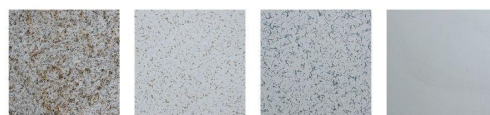
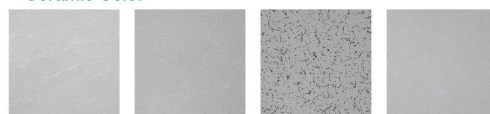

» Granite Color



G664

G603

G604

» Anti-static HPL Color Shade Card



XL-2010

XL-2010-1

XL-2010-4

XL-2010-8

XL-2103

XL-2069

» Carpet Color(500x500mm,600x600mm)



Construction Disposal And Use Notice

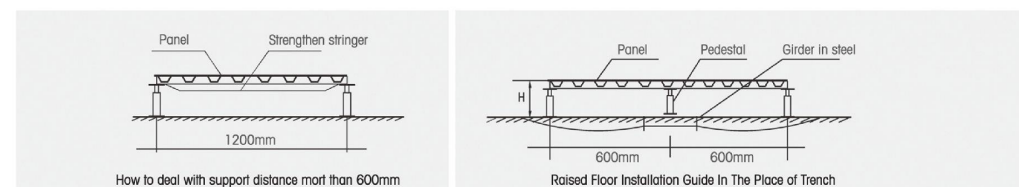
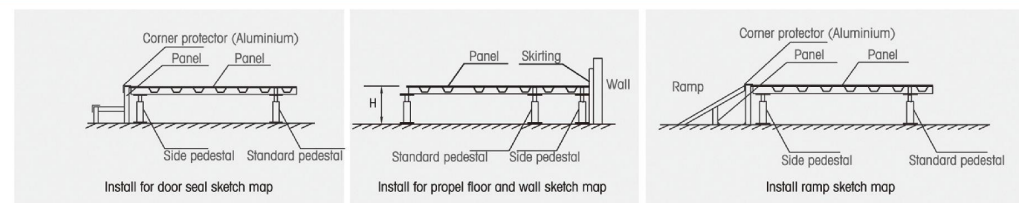

Maintenance

Please read instruction book carefully before installation

Environmental requirements for applicable fields:

Temperature :10~30℃(5~35℃ for OA Steel Raised Floor)

Relative humidity:RH30~70%

Temperature change rate:ΔT≤15℃/per hour without clotted dew;

Vibration:There is no frequent vibration(Resource)

Chemical Environment:There is no high corrosion volatile substance,Water wash is prohibited fir cleaning the surface of raised floor.Dry mop shall be used to clean it to prevent surface of raised floor from being desquamated and metal pars under it from being rusted and corroded.

- 1.It is forbidden to use hard or sharp things to extrude,impact or scratch the cover of floor and plastic -sprayed layer.
- 2.Special panel lifter shall be used for opening or installing raised floor gently.Don't use iron tools to pry up it urgently.
- 3.In the busy area such as corridor,gateway etc,excessive load should be avoided.Otherwise the floor will be easily damaged.
- 4.With regard to long period of heavy load,auxiliary support shall be added at the relative part of floor if the weight of one foot of machine nearly reached or is bigger than 1/3 of loading capacity of the floor.
- 5.Sound may be heard when walking on the floor after it is laid.It is cause by ground condition and installation problem, not by performance and quality of floor itself.
- 6.Don't use excessive heavy things,which can damage the floor.
- 7.Don't move the floor while it is lifting,which may make it fall off.
- 8.Gloves must be worn when taking the floor.Otherwise hands are easily hurt by it.
- 9.Avoid sun light shining it directly so as to prevent cover layer from changing color and aging earlier.
- 10.Please don't lay down gas pipes and water pipes under the floor.